



Plastics Automation



**EXCELLENCE IN**  
**PLASTICS AUXILIARY EQUIPMENT**  
AND SYSTEM SOLUTIONS

---

# SMART INTEGRATED AUTOMATION SOLUTIONS

---

For The Global Plastics Industry





Plastics Automation

## CORPORATE OVERVIEW

Since our inception in 1998, Aerodry has been at the forefront of advanced plastics auxiliary equipment and intelligent automation solutions, empowering manufacturers to achieve higher productivity, superior quality, and enhanced operational efficiency. What began as a focused entrepreneurial venture has evolved into a globally trusted partner, delivering innovative auxiliary equipment and smart process automation systems across diverse industry segments.

For nearly three decades, Aerodry has been a cornerstone of the plastics processing industry - bridging cutting-edge technology with personalized service. Our solutions are engineered to deliver unmatched reliability, efficiency, and performance, enabling our customers to stay competitive in an ever-evolving manufacturing landscape.

Aerodry offers a comprehensive portfolio spanning the entire production lifecycle, including drying, conveying, dosing and blending, temperature control, recycling, and turnkey automation solutions. Through our strategic joint venture with Ferlin Plastics Automation B.V., Netherlands, we combine world-class engineering with international quality benchmarks. Supported by ISO 9001-certified manufacturing facilities in Noida and Greater Noida, and a strong commitment to CE-marked excellence, Aerodry stands by its vision of "Leadership Through Excellence", redefining performance standards across global markets.

**At Aerodry, we don't just supply equipment - we deliver a competitive edge that maximizes uptime, optimizes productivity, and drives long-term success.**

# TABLE OF CONTENTS

Mission, Vision, Milestones	02-03
Dosing & Blending Solutions	04-08
Extrusion Process Control	09-10
Drying Solutions	11-14
Crystallizing Solutions	15-16
Conveying Solutions	17-24
Heating & Cooling Solutions	25-28
Turnkey Automation	29
Installations	30-32

# Company

## Mission & Vision

### Our Mission

- To design and manufacture high-performance plastics auxiliary equipment and process automation solutions that enhance productivity with utmost quality consistency.
- To provide customized, end-to-end product solutions aligned with customer needs.
- Focused investment in plant and machinery, R&D technology, human resources capital and all business partners.
- To deliver consistent value through innovative product quality with fastest return on investment for our valued customers.



### Our Philosophy & Approach

We operate on a simple yet powerful philosophy:

Understand the end to end process to identify the potential gaps, current challenges for the customer in order to deliver an innovative solution that not only addresses the process needs but also adds value to the business.



Plastics Automation

### Our Vision

To be a globally recognized leader in plastics auxiliary equipment and process automation solutions by delivering innovative, energy-efficient and reliable technologies that enable smarter manufacturing for the consistently growing plastics processing industry sector.

### Our Main Focus Areas Are

- Deep understanding of customer processes and challenges.
- In-house design, engineering, and manufacturing capabilities.
- Focus on efficiency, energy savings, and operational reliability.
- Long-term partnership mind-set rather than one-time sales.
- Deliver highest value proposition instead of just a product solution.
- Ensure every solution we deliver is practical, scalable, and future-ready.

# Key Milestones



## 1998 – Founded & First Step

- Founded on 9th April 1998 and got legally incorporated as Pvt Ltd Company.



## 1999 – From humble beginnings to assembling in house

- After one year of inception, a small assembly unit with working area of 3500 square feet and additional office space of 2000 set up in Noida sector 8. Started assembling Hot air Driers, Dehumidifying Driers and Auto Loaders.



## 2001 – Quality Commitment

- The youngest company to be awarded ISO 9001 certification in equipment manufacturing, embedding quality in every process.



## 2004 – Our Global Outreach.

- Signed technology partnership agreement with DE. GA. S.p.A (Italy) on 10th May 2004 to add and manufacture innovative centralised conveying system and dosing units, MTC etc.
- Partnership agreement with Harmo Company Ltd (Japan) to offer pick & place robots for Indian market.



## 2005 – First Centralised Plant

- Successfully installed and commissioned first indigenously built centralised drying and conveying system for a leading automotive component manufacturer in Pune for 48 injection moulding machines.



## 2008 – Expansion Unit 2 started.

- Expanded manufacturing with the start of an in-house sheet metal and powder coating at a second facility at F-52 sector 11 Noida. From sheet metal design, fabrication to powder.

## 2009 – Expansion into Extrusion Portfolio

- Signed a Joint Venture agreement on 25th May 2009 with Ferlin Plastics Automation BV (Netherlands) for manufacturing of advanced Innovative Gravimetric Batch Blenders in order to cater to all segments of plastics processing industry.
- Signed a Technology agreement with Bolder Automation GmbH (Germany) for manufacturing of loss in weight Extrusion Process Control systems in India.

## 2010 – First kg/m Control System

- First loss in weight kilo gram per meter control system for major gas pipeline projects in multiple locations.

## 2011 – Industry-first Silo-to Gravimetric Blender Centralised System

- First centralised conveying, from silo to Gravimetric blending for advanced drip irrigation project for 9 Extrusion lines.

## 2012 – Centralized Project for AD Star Bag

- Installed and commissioned first centralised drying, conveying, gravimetric blending for a major AD star bag project with multiple Starlinger tape Extrusion lines at Jaipur.

## 2019 – Manufacturing Plant Expansion

- By adding a new facility at F-53 in addition to our existing facility at F-52, Sector 11, Noida.

## 2025 – Greater Noida Expansion

- Expanded footprint with a new state-of-the-art facility at B-29, Ecotech VI, Greater Noida, significantly enhancing capacity and technology integration.



# DOSING & BLENDING SOLUTIONS

Engineered for Accuracy. Built for Performance.



With **10,000+ installations globally** and adoption by leading OEMs, the AGB Series is a trusted solution for manufacturers seeking accuracy, efficiency, and process control.

# Gravimix NECS, MECS & FLECS

The Gravimix NECS, MECS and FLECS gravimetric blenders are compact, high-precision solutions engineered for efficient blending of raw materials, additives and regrind in space-restricted processing environments. With these, you can save additives up to 35%.

NECS and MECS are ultra-compact solutions designed for direct mounting on injection molding machines, delivering reliable gravimetric blending. FLECS builds on the same compact footprint and easy cleanability, offering mid-range capacity and hybrid compatibility across injection molding, blow molding and extrusion lines - ensuring stable, repeatable blending performance with enhanced operational flexibility.

## Salient Features

1. Best in class accuracy of 0.01%
2. Rugged European design and stainless steel construction
3. Patented easy cleaning technology
4. In built regrind control for increased additive savings
5. Microprocessor based control
6. Software to run and operate multiple Gravimix in multiple plant locations
7. Easy operator interface available through any smart device for recipe recall and run option
8. Availability of key reports such as shift wise production, alarm history, recipe run, material consumption through software
9. Available in machine mounted or stand mounted configurations
10. Optional high temperature model for specialized applications

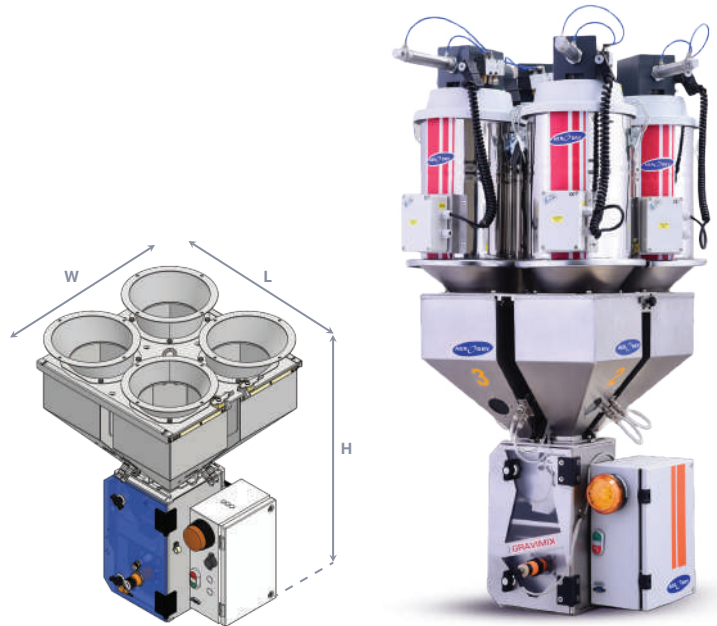

## Technical Specifications:

MODEL	NUMBERS OF COMPONENTS	BATCH SIZE (KG)	CAPACITY (KG/H) max*	DIMENSION (mm)			WEIGHT (KG.) APPROX	MIXING CHAMBER VOLUME (LTR)
				L	W	H		
GRAVIMIX NECS	2-4	0.2	25	344	344	556	25	0.5
GRAVIMIX MECS	2-4	0.7	110	650	600	770	44	3.2
GRAVIMIX FLECS	2-4	1.8	300	700	655	885	60	7

\*All specifications are subject to change due to continuous R&D

# Gravimix 2/5/7

The Gravimix 2, 5 & 7 gravimetric blenders are mid-range, high precision solutions for efficient blending of raw material and additives for high output extrusion lines applications.

AGB 2, 5 & 7 are available to feed single/multiple extrusion lines. Their compact footprint makes them the preferred choice of the industry. Easy to use stroke restrictor as well as easy cleaning hoppers can be integrated to provide additional flexibility during recipe changeover times.

## Salient Features

1. Best in class accuracy of 0.01%
2. Rugged European design and stainless steel construction
3. Patented easy cleaning technology
4. In built regrind control for increased additive savings
5. Microprocessor based control
6. Software to run and operate multiple Gravimix in multiple plant locations
7. Easy operator interface available through any smart device for recipe recall and run option
8. Availability of key reports such as shift wise production, alarm history, recipe run, material consumption through software
9. Available in machine mounted or stand mounted configurations
10. Optional high temperature model for specialized applications



## Technical Specifications

MODEL	NUMBERS OF COMPONENTS	BATCH SIZE (KG)	CAPACITY (KG/H) max*	DIMENSION (mm)			WEIGHT (KG.) APPROX	MIXING CHAMBER VOLUME (LTR)
				L	W	H		
GRAVIMIX AGB 2	2-8	4.2	700	954	955	1050	80	15
GRAVIMIX AGB 5	2-8	5.7	1100	954	954	1268	110	20
GRAVIMIX AGB 7	2-8	8	1450	1325	975	1569	175	45

\*All specifications are subject to change due to continuous R&D

# Gravimix 10/25

The Gravimix 10 & 25 are high throughput models suitable for central or local installation for extrusion lines having higher throughputs. They are available for blending of 2 to 10 raw materials and/or additives.

These models are more suited for floor mounted installations. Built for demanding, high-throughput operations, it combines robust construction, simple operation, and optional interface for seamless integration with plant-level control systems - leading to long term reliability.

## Salient Features

1. Best in class accuracy of 0.01%
2. Rugged European design and stainless steel construction
3. In built regrind control for increased additive savings
4. Microprocessor based control
5. Software to run and operate multiple Gravimix in multiple plant locations
6. Easy operator interface available through any smart device for recipe recall and run option
7. Availability of key reports such as shift wise production, alarm history, recipe run, material consumption through software
8. Available in platform mounted or stand mounted configurations
9. Optional high temperature model for specialized applications



## Technical Specifications

MODEL	NUMBERS OF COMPONENTS	BATCH SIZE (KG)	CAPACITY (KG/H) max*	DIMENSION (mm)			WEIGHT (KG.) APPROX	MIXING CHAMBER VOLUME (LTR)
				L	W	H		
GRAVIMIX AGB 10	2-7	10	2000	1349	1322	1629	300	56
GRAVIMIX AGB 25	2-8	25	3210	1500	1735	2150	400	99

\*All specifications are subject to change due to continuous R&D

# Volumetric Dosing Units

ADU Series volumetric dosing and blending unit offers automation with economy for dosing and blending of additives in granular/pellet forms. These are suitable for all plastic processing sectors. This can be integrated with extrusion as well injection molding machines for synchronized operations.

## Salient Features

1. Microprocessor based control
2. Direct dosing – eliminating separation of additives during conveying
3. Easy to calibrate for accurate dosing
4. Reliable, maintenance-free stepper motor
5. Light weight construction with durable powder coated finish
6. Robust stainless steel construction
7. Built in alarm for auto load facility
8. Provision to save up to 200 recipes
9. Can be supplied with additional blending unit



## Technical Specifications

MODEL	UNIT	ADU-TEST/EXT	ADU-AP/EXT	ADU-GR/EXT
Applicable Dosing Range (Screw Size)	S-12	2.1		2.1
	S-16	5.5		7.5
	S-20	18/24		25
	S-24	28/41		41
	S-30	28/41	62	62
	S-35	28/41	112	112
	S-40	28/41	203	203
	S-50		380	380
Hopper Volume	Ltr	15	50	50
Operating Voltage	V	220/50 Hz		
Connected Load	W	200	750	500
Unit Wt. (Approx)	kg	10	20	20

\*Extrusion Model

All specifications are subject to change due to continuous R&D

# EXTRUSION PROCESS CONTROL

Less variation. More reliability.



Designed to minimize variation and improve operational efficiency, Aerodry's **Extrusion Process Control** systems help achieve stable extrusion performance consistently and reliable output across production runs.

# Extrusion Process Control

**Extrusion Process Control** solutions are based on the loss in weight principle. These solutions are widely used for blend control in co-extrusion, blow molding and pipe extrusion for controlling the weight per meter and self-corrective blend feeling through control of extruder haul off.

Incorporation of extrusion process control ensures consistency in quality of end product and substantial cost saving.

## Salient Features

1. High blending stability
2. Equal layer distribution in co-extrusion
3. Constant extruder feeding
4. Material savings
5. Precise measurement, optimal control
6. Adaptive hopper refilling
7. Adaptive control
8. Start up and change of working points in control
9. Configurable alarms
10. Supervision and control of the drive module



## Technical Specifications

VOLUME	(l)	LIW												
		2	3	3	4,5	6	9	12	15	24	30	40	60	100
Max. throughput polyolefins on $\rho=0.55\text{kg/m}^3$	kg/h	40	60	60	90	120	200	250	300	480	600	800	1200	2000
Max. throughput regrind on $\rho=0.35\text{kg/m}^3$	kg/h	--	--	40	55	75	125	160	190	300	380	500	750	1300
Hopper size D	mm	150	150	240	240	240	240	240	240	400	400	400	600	600
Width	mm	338	338	380	380	380	380	380	380	505	505	505	705	705
Depth	mm	200	200	300	300	300	300	300	300	430	430	430	650	650
Height	mm	575	645	650	670	710	770	735	900	920	1000	1100	1130	1275

\*All specifications are subject to change due to continuous R&D

# DRYING SOLUTIONS

Consistent drying. Superior results.



Efficient, reliable drying is essential for quality plastics processing. **Aerodry's range of drying technologies** supports both hygroscopic and non-hygroscopic materials, ensuring optimum moisture removal for downstream processing.

# Hot Air Dryers

The IHD Series Hot Air Dryers are specifically designed for efficient pre heating and drying of plastics and petrochemical materials in pellet and granular form. Designed to support consistent and stable processing conditions, the system ensures uniform heat distribution and effective moisture removal to maintain material integrity and process reliability. The fully insulated drying chamber minimises heat loss and enables precise temperature control throughout the drying cycle – all while consuming less energy as compared to the conventional non-insulated hot air dryers.

## Salient Features

1. Uniform air distribution system ensures uniform and efficient pre-heating and drying
2. PID temperature controller with display set and actual process temperature
3. Robust stainless steel construction
4. Airflow control dampers are provided with filter wire mesh to prevent entry of dust and foreign particle into the hopper.
5. Double-walled, insulated construction minimizes heat loss & delivers energy savings of up to 60%.
6. Easy-access cleaning window with sight glass enables quick inspection and maintenance.
7. Lightweight aluminium blowers with an optimised air-to-material ratio ensure faster drying.
8. Safety thermostat provides additional protection against overheating and material clogging



## Technical Specifications

MODEL	UNIT	IHD 15	IHD 25	IHD 50	IHD 75	IHD 100	IHD 150	IHD 200	IHD 300	IHD 400	IHD 500	IHD 800	IHD 1000	
Drying Capacity	kg/Hr	15	25	50	75	100	150	200	300	400	500	800	1000	
Process Blower	kW	0.09	0.09	0.18	0.18	0.37	0.37	0.37	0.37	0.75	0.75	0.75	1.5	
Process Heater	kW	2	3	4.5	4.5	6	6	9	9	18	18	27	27	
Volume	LTR	30	50	90	125	170	245	340	480	680	830	1250	1700	
Cleaning Window	-	NOT APPLICABLE					STANDARD							
Controls	-	PID												
Power supply	V/Hz/Ph	415V / 50 Hz / 3Ph												
Diameter	φ	324	404	484	484	594	594	669	754	844	844	1000	1080	
	L	mm	570	644	644	644	950	950	995	1080	1350	1350	1625	1610
Dimensions	W	mm	500	564	724	724	650	650	725	810	950	950	1200	1260
	H	mm	830	895	1010	1210	1335	1490	1655	1740	2270	2570	2800	3250

# Dehumidifying Dryers

The **EAD Series Dehumidifying Dryers** are engineered for precise drying and pre-heating of hygroscopic plastics where moisture control is critical. Operating on a closed-loop system, EAD dryers deliver consistently low dew points below  $-55^{\circ}\text{C}$  independent of ambient conditions - ensuring superior material conditioning, stable processing, and defect-free moulding.

## Salient Features

- PLC / Microprocessor-Based Control System
- Real-time display for monitoring temperature, airflow, and system status.
- Online dew point monitoring & Closed-Loop Drying
- Swiss Molecular Sieve (Beaded Form).
- Highly efficient cartridge filters for both drying & regeneration side.
- Modular designs with multiple drying hoppers.
- Integrated process heater bank within insulated hopper for improved efficiency and power savings.
- A unique air distribution system ensures more efficient drying.
- Return air cooler to maintain consistent drying conditions.
- Auto changeover valve system to provide seamless switching between desiccant beds
- SS-304 Insulated Drying Hoppers with Viewing Windows
- Heat recovery system for high heat models.



## Technical Specifications

MODEL	UNIT	EAD 50	EAD 80	EAD 120	EAD 200	EAD 300	EAD 400	EAD 500	EAD 800	EAD 1000	EAD 1500	EAD 2000	EAD 2500	
Drying Capacity	m <sup>3</sup> /hr.	50	80	120	200	300	400	500	800	1000	1500	2000	2500	
Dry Air Temperature	°C	Std. Upto 140 °C (High heat upto 180 °C)												
Process Blower	kW	0.4	0.75	0.75	1.5	2.2	2.2	4.0	5.5	7.5	7.5	11.0	15.0	
Process Heater	Standard Heat	kW	2.0	3.0	4.5	6.0	9.0	9.0	15.0	18.0	18.0	27.0	36.0	45.0
	High Heat	kW	3.0	4.5	6.0	9.0	12.0	12.0	18.0	27.0	27.0	36.0	45.0	54.0
Regeneration Heater	kW	3.2	3.0	4.5	6.0	9.0	9.0	12.0	18.0	18.0	27.0	36.0	45.0	
Average Power Consumption(Approx)	kW	2.7	3.4	4.9	6.8	10.1	10.1	15.5	20.8	21.8	30.8	41.5	52.5	
Dew Point	°C	(-55°C)												
Dimensions	L	mm	650	850	850	1100	1150	1150	1150	1670	1670	1670	2700	2700
	W	mm	550	800	800	1000	1000	1000	1000	1400	1400	1400	1600	1600
	H	mm	1300	1600	1600	1900	1950	1950	2100	2450	2450	2450	2300	2450
Weight (Approx.)	kgs.	90	225	250	400	750	800	925	1030	1030	1070	1350	1500	

\*All specifications are subject to change due to continuous R&D

## Optional Features

- Online dew point display
- Seven-day digital timer
- Heat recovery system (high-heat models)
- Flow meters for individual hopper airflow monitoring
- Return air cooler
- Higher airflow capacity models on request

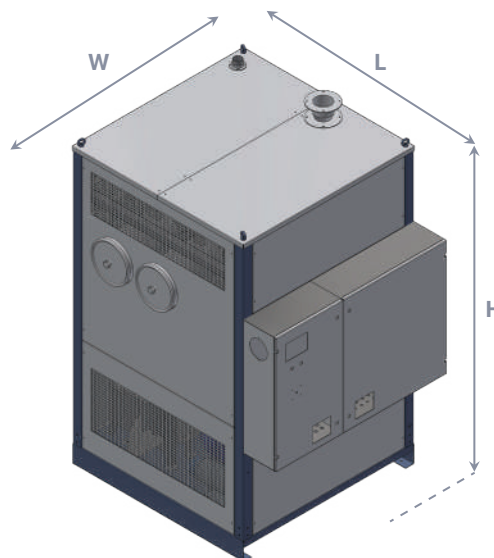

## Material Drying Chart

Material	Drying Time (Hr.)	Temp (°C)	Bulk Density (kg/dm <sup>3</sup> )	EAD 30	EAD 50	EAD 80	EAD 120	EAD 200	EAD 300	EAD 400	EAD 500	EAD 1000	EAD 1500	EAD 2000	EAD 2500
ABS	2.5	80	0.63	17	28	44	67	111	167	222	278	556	834	1112	1390
CA	2.8	65	0.78	12	20	32	48	80	120	160	200	400	600	800	1000
CP	2.5	70	0.74	12	20	32	48	80	120	160	200	400	600	800	1000
PA	3	75	0.62	14	23	36	55	91	136	182	227	455	681	908	1135
PBT	3.5	120	0.81	17	28	44	67	111	167	222	278	556	834	1112	1390
PC	3	120	0.72	17	28	44	67	111	167	222	278	556	834	1112	1390
PEEK	4	160	0.79	17	28	44	67	111	167	222	278	556	834	1112	1390
PE (Filled)	3	90	0.57	20	33	53	80	133	200	267	333	667	801	1068	1335
PES	3.5	150	0.82	15	25	40	60	100	150	200	250	500	750	1000	1250
PET	4	125	0.84	12	20	32	48	80	120	160	200	400	600	800	1000
PMMA	3.5	80	0.71	17	28	44	67	111	167	222	278	556	834	1112	1390
POM	2.5	100	0.85	17	28	44	67	111	167	222	278	556	834	1112	1390
PP	1.5	90	0.54	20	33	53	80	333	200	267	333	667	801	1068	1335
PPO	2.5	100	0.64	17	28	44	67	111	167	222	278	556	834	1112	1390
PPS	3.5	150	0.8	20	33	53	80	133	200	267	333	667	801	1068	1335
PS	1.5	80	0.63	21	36	57	86	143	214	286	357	714	1071	1428	1785
PSU	2.5	140	0.74	20	33	53	80	133	200	267	333	667	801	1068	1335
PUR	2.5	90	0.73	12	20	32	48	80	120	160	200	400	600	800	1000
PVC	1.5	70	0.81	17	28	44	67	111	167	222	278	556	834	1112	1390
SAN	2.5	80	0.65	17	28	44	67	111	167	222	278	556	834	1112	1390
SB	1.5	70	0.63	20	33	53	80	133	200	267	333	667	801	1068	1335
TPE	3	100	0.71	12	20	32	48	80	120	160	200	400	600	800	1000

# CRYSTALLIZING SOLUTIONS

Consistent Quality PET. Performance Assured.



CHD Series Crystallizer precisely controls the crystallization process to achieve crystal-clear PET with consistent material properties, while minimizing process variations and ensuring stable performance.

# Crystallizers

**CHD Series Crystallizers** are used for continuous crystallization of amorphous PET in the form of bottle flakes or chips.

**Crystallization** process is necessary prior to processing of recycled PET, as it not only helps in better processing of recycled PET but also helps avoid lump formation during drying at high temperature. The agitator hopper is equipped with a strong arm agitator which rotates at slow RPM to crystallize the material. The system is equipped with various sensors to ensure uniform crystallization of the material for further processing in extrusion or injection molding process.

## Salient Features

1. Crystallizer hopper in stainless steel MOC
2. Soft start up program for auto or manual mode
3. Extra strong agitator arm to ensure long life
4. Sensors to ensure even crystallization
5. Removable section of cone – ensuring easy maintenance
6. Inbuilt primary and secondary conveying for direct use
7. Energy saving option built in the system
8. User friendly PLC controls
9. Inbuilt dust separator
10. Open or close loop system as per application
11. Can be used standalone or with processing machine
12. Dehumidifier can be offered as per application (optional)



## Technical Specifications

MODEL	UNIT	CHD-400	CHD-500	CHD-800	CHD-1000	CHD-1500	CHD-2000	
Throughput*	kg/hr	60	120	350	475	625	750	
Agitator Bin Volume	Ltr	200	500	800	1000	1500	2000	
Connected Load	kW	12	21	36	48	72	72	
Power Supply	(V/Hz/Ph)	415/50/3						
Dimensions	L	mm	1750	1750	1750	1750	2500	2500
	W	mm	1000	1000	1150	1150	1400	1400
	H	mm	3900	3900	3900	3900	4500	4500
Weight	kg.	300	450	800	1000	1300	1500	

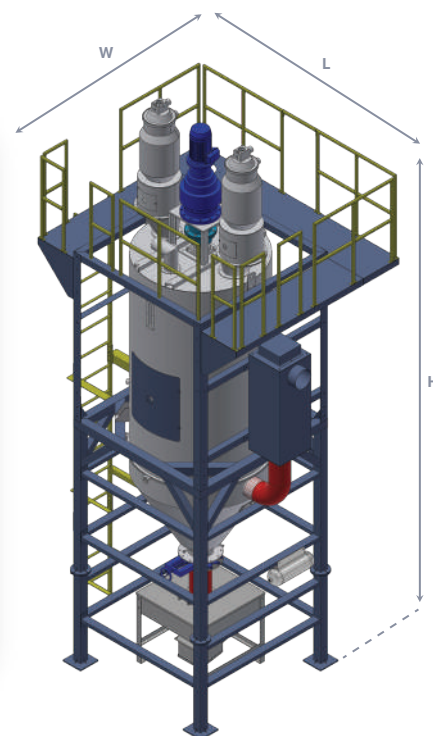

\*Bulk density is considered 0.8 kg/m<sup>3</sup>  
 All specifications are subject to change due to continuous R&D

# CONVEYING SOLUTIONS

Smart Conveying. Seamless Processes.



**Conveying solutions** designed for smooth and efficient material transfer across the production line, ensuring controlled flow, minimal material degradation, and stable operations.

# Hopper Loaders

**Aerodry AVL Series Hopper Loaders** are engineered for reliable, high-performance conveying of plastic granules and regrind in demanding industrial environments. Designed with robust construction and precision-engineered components, the AVL Series ensures **consistent, contamination-free material transfer** to single or multiple processing machines.

With **modular configurations** ranging from **machine-mounted loaders to centralized multi-station** systems, AVL Loaders optimize material distribution, reduce manual handling, and improve overall plant efficiency. They are available in various configurations – ratio, duo, tria, quatra, penta and hexa series.

## Salient Features

1. Side channel blower with silencer for silent operation
2. Microprocessor based control
3. SS flapper valve with level switch
4. Cyclone made of SS304 MOC with mirror finish
5. Easy to handle pickup nozzle
6. Dual filters to avoid dust
7. Audiovisual alarm to draw operator’s attention
8. Audiovisual alarm for empty bin



## Technical Specifications

MODEL	UNIT	AVL-100 E	AVL-200 E	AVL-500 E	AVL-800 E	AVL-1000 E	AVL-2000 E	
Max. Capacity*	kg/hr	150	300	600	1000	1250	2000	
Conveying Height	meter	4	5					
Conveying Distance (Max)		5						
Conveying Pipe Size	mm	40		50			63	
Vacuum Pipe Size		50				63	76	
Blower Rating	kW	0.9	1.5	2.2	4	5.5	7.5	
Power Requirement	V/Hz/Ph	415 V/ 50 Hz/ 3 Phase						
Type of Mounting		Split						
Cyclone	LTR	CS-3		CS-5			CS-10	
Weight (Approx.)	kgs	35	50	52	55	150		
Skid Dimensions	L	450					850	
	W	360					600	
	H	950					1950	

## Hopper Loader Duo (AVL-D Series)

**Duo Hopper Loaders** are suitable for double material transfer from material bin to dryer or processing machine.

### Technical Specifications

MODEL		UNIT	AVL-100 D	AVL-200 D	AVL-500 D	AVL-800 D	AVL-1000 D	AVL-2000 D
Max. Capacity*		kg/hr	150	300	600	1000	1250	2000
Conveying Height		meter	5					
Conveying Distance (Max)								
Conveying Pipe Size		mm	40		50			63
Vacuum Pipe Size			63					
Blower Rating		kW	1.5	1.5	2.2	4	5.5	7.5
Power Requirement		V/Hz/Ph	415 V/ 50 Hz/ 3 Phase					
Type of Mounting			Split					
Cyclone		LTR	CS-3 X2			CS-5 X2		CS-10 X2
Weight (Approx.)		kgs	90	95	105	110	150	
Skid Dimensions	L		500				850	
	W	mm	450				600	
	H		1450				1950	

\*All specifications are subject to change due to continuous R&D

## Hopper Loader Tria (AVL-T Series)

**Tria Hopper Loaders** are suitable for material transfer of three materials from material bin to processing machine

### Technical Specifications

MODEL		UNIT	AVL-100 T	AVL-200 T	AVL-500 T	AVL-800 T	AVL-1000 T	AVL-2000 T
Max. Capacity*		kg/hr	150	300	500	600	800	1600
Conveying Height		meter	5					
Conveying Distance (Max)								
Conveying Pipe Size		mm	40		50			63
Vacuum Pipe Size			63					
Blower Rating		kW	1.5	2.2		4	5.5	7.5
Power Requirement		V/Hz/Ph	415 V/ 50 Hz/ 3 Phase					
Type of Mounting			Split					
Cyclone		LTR	CS3 X3		CS5 X2, CS3 X1		CS-5 X3	CS-10 X3
Weight (Approx.)		kgs	90	105		110	150	
Skid Dimensions	L		500				850	
	W	mm	450				600	
	H		1450				1950	

\*All specifications are subject to change due to continuous R&D

## Hopper Loader Quatra (AVL-Q Series)

Quatra Hopper Loaders are suitable for material transfer of four materials from material bin to processing machine

### Technical Specifications

MODEL	UNIT	AVL-100 Q	AVL-200 Q	AVL-500 Q	AVL-800 Q	AVL-1000 Q	AVL-2000 Q
Max. Capacity*	kg/hr	150	200	500	800	1250	2000
Conveying Height	meter	5					
Conveying Distance (Max)							
Conveying Pipe Size	mm	40	50				63
Vacuum Pipe Size		63					76
Blower Rating	kW	2.2	4		5.5	7.5	
Power Requirement	V/Hz/Ph	415 V/ 50 Hz/ 3 Phase					
Type of Mounting		Split					
Cyclone	LTR	CS-3 x 4			CS3 x 2 CS5 x 2	CS-5 x 4	
Weight (Approx.)	kgs	105	110			150	
Skid Dimensions	L	500				850	
	W	450				600	
	H	1450				1950	

\*All specifications are subject to change due to continuous R&D

## Hopper Loader Penta & Hexa (AVL P/H-Series)

Penta/Hexa Hopper Loaders are suitable for material transfer of 5/6 materials from material bin to processing machine

### Technical Specifications

MODEL	UNIT	AVL-500 P	AVL-800 P	AVL-1000 P	AVL-500 H	AVL-800 H	AVL-1000 H
Max. Capacity*	kg/hr	600	750	1100	500	750	1000
Conveying Height	meter	5			5		
Conveying Distance (Max)							
Conveying Pipe Size	mm	50			50	63	
Vacuum Pipe Size		63					
Blower Rating	kW	4	5.5	7.5	4	5.5	7.5
Power Requirement	V/Hz/Ph	415 V/ 50 Hz/ 3 Phase			415 V/ 50 Hz/ 3 Phase		
Type of Mounting		Split			Split		
Cyclone	LTR	CS-3 X3 CS5 X2	CS-5 X5		CS3 X4 CS5 X2	CS5 X6	
Weight (Approx.)	kgs	110	150		110	150	
Skid Dimensions	L	500	850		500	850	
	W	450	600		450	600	
	H	1450	1950		1450	1950	

\*All specifications are subject to change due to continuous R&D

# Centralized Conveying System

The **CCS Series** centralized conveying systems are fully automatic systems for raw material conveying from debagging stations to silos and further to extruders, injection and blow molding machines in the plastics processing industry.



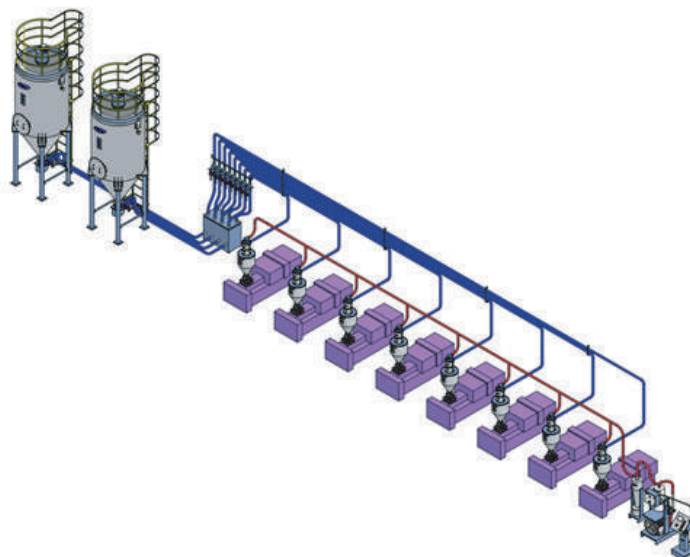

This system helps in material saving by efficient material conveying as well as ensures a state of the art plant aesthetic. It is modular in nature which makes it viable for future expansion plans and makes it a unique choice over conventional auto loader for individual machines.

## Salient Features

1. Touch screen PLC control
2. Available range from 8 upto 100 stations
3. SS flapper valve with level switch
4. Dual filters to avoid dust
5. Audiovisual alarm to draw operator's attention
6. Networking between central blower station and cyclones
7. Expandable into multiple blower stations with single control system
8. Line cleaning valves for automatic flushing of material lines
9. Proportionate valves for regrind mix control
10. Auto/manual material changeover systems for quick material change
11. Day bins equipped with multiple outlet vacuum suction box
12. Connectivity with automatic dosing & blending and other auxiliary equipment

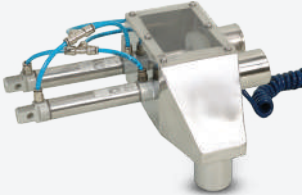

# Conveying Accessories

PRODUCT NAME	DESCRIPTION	
<b>Raw Material Day Bins</b>	Aerodry ADB Series day bins are available for in-plant transit material storage to help save labor and material while keeping the plant aesthetics. Day bins help in avoiding material spillages by keeping the loading/unloading of the material in a localized area. Day bins are available in SS304/Aluminum raw material options.	
<b>Suction Box</b>	Aerodry suction box are available from 1 to 12 way with further expandability options. Pneumatic type suction box are suitable for dried material conveying without exposure to atmospheric air.	
<b>Line Cleaning Valve</b>	Aerodry line cleaning valves are specially designed for cleaning the raw material line to avoid contamination of material during conveying in centralised conveying plants. Customised line cleaning valves are offered to suit different project requirements.	
<b>Proportionate Valve</b>	Aerodry proportionate valves are designed to convey two materials like virgin or regrind in a given proportion during conveying. Proportionate valve is a cost effective solution to convey virgin and regrind material without manual mixing. It also helps avoid material separation during the conveying due to bulk density difference of virgin and regrind material.	
<b>Selection Table</b>	Aerodry selection tables are available in different options for easy material change manually or automatically. Selection tables help user with easy material changeovers without wastage of time. Automatic selection table also helps in bar code scanning of a particular material to ensure the right material feeding.	
<b>Material Cyclone</b>	Aerodry material cyclone is used to separate the plastic material from the conveying air.	

\*All specifications are subject to change due to continuous R&D

# Pressure Conveying System

**Pressure Conveying System** works on positive pressure where an air blower is used to supply air and material is controlled through a rotary air lock valve/venturi system to control the feed of raw material into the pipeline.

These systems are designed for rapid silo filling of bulk materials. They can feed single or multiple silos using various control mechanisms. Aerodry offers a wide range of pressure conveying systems from 2 TPH to 25 TPH, covering distances of 50-100 meters.

These systems are fully automatic and are controlled through a PLC. Debugging stations can be offered with a provision for 25 kgs bags or big bags.

## Salient Features

1. Integrated PLC control
2. Debugging station in SS304 MOC
3. Positive displacement pump with safety valve
4. Instrumentation such as pressure switch, pressure indicator, level switch
5. Rotary lock valve/venturi included in the system
6. Automatic changeover through diverter valve
7. Option for manual changeover through quick release couplings
8. Noise level at 80 dB
9. Optional instrumentation such as radar type switch, silo level switches can be integrated
10. Suction box available on request
11. Big bag emptying station (optional)
12. Claw pump (optional)

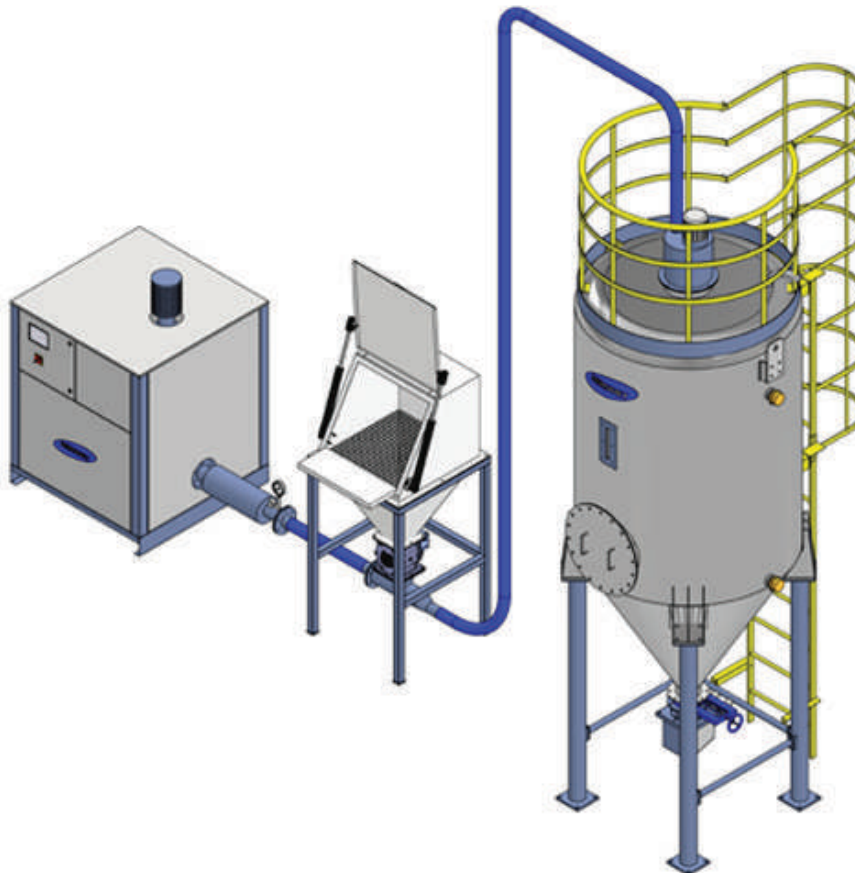

# Powder Conveying System

**Powder Conveying Systems** are used to convey fine/coarse powders from storage silos or bins to extrusion and or injection molding lines.

Material is conveyed from storage silo to processing machine through vacuum conveying system using negative pressure. These types of systems can be used to convey material from single pickup point to multiple machines or from multiple pickup points to single machine.

Powder conveying system can also be used to fill silos through positive pressure which is called pressure conveying or dense phase conveying systems. These systems can be tailored to a specific plant's requirement and can be integrated with upstream and downstream automation.

## Salient Features

1. Integrated PLC control
2. Instrumentation such as pressure switch, pressure indicator, level switch
3. Cyclone in stainless steel MOC with automatic filter cleaning
4. Rotary lock valve with pneumatic actuator
5. Automatic level control
6. Option of side channel/claw pump
7. Central filtration system with reverse pulse jet cleaning
8. Debagging station with dust control
9. Big bag emptying station with automatic discharge (optional)
10. System available in multiple configurations as per plant requirement

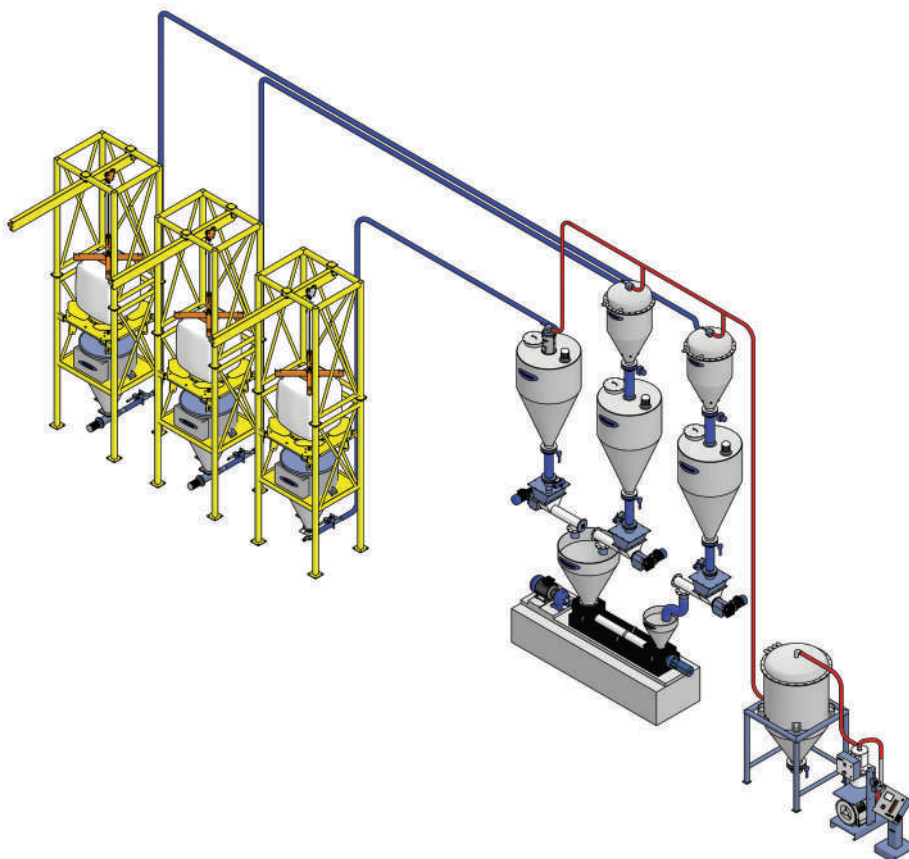

# HEATING & COOLING SOLUTIONS

Reliable Thermal Control for Industrial Processes



Designed for plastics processing industry, **Aerodry's heating and cooling solutions** deliver precise thermal control, faster cycles, and reliable continuous operation.

# Mold Temperature Controllers

TAC Series Mold Temperature Controllers are ideal for heating/cooling with water or thermic oil as the heat transfer media for maintaining temperature in various applications of plastic molding and extrusion process with precise temperature control.

## Salient Features

1. European anti-corrosive pump
2. Inbuilt auto cooling circuit to avoid temperature surge
3. Audiovisual alarm to draw operator's attention
4. Insulated SS304 oil/water tank
5. Inbuilt vent with oil/water filling cap
6. Overload and level protection for pump
7. Dual temperature safety
8. Switchable from oil to water mode
9. PID temperature controller
10. Forward reverse mold drainage facility available
11. Large size PHE model for special application (optional)
12. High pressure water based model upto 140°C (optional)



## Technical Specifications (Water Based – Upto 90°C)

MODEL	UNIT	TAC-3W	TAC-6W	TAC-9W	TAC-12W	TAC-18W	TAC-27W
Heating Capacity	kW	3	6	9	12	18	27
Outlet Temp. Range <sub>(Max.)</sub>	°C	10 to 90					
Tank Capacity	Ltr	4	4	6.5	9	9	15
Pump Motor	kW	0.33	0.33	0.75	1.5	1.5	2.2
Flow Rate <sub>(Max.)</sub>	LPM	20-40	20-40	20-60	50-200	50-200	110-280
Pump Pressure <sub>(Max.)</sub>	bar	3.8	3.8	5.9	3.3	3.3	3.5
Cooling		Direct Cooling					
Operating Voltage	V/Hz/Ph	415/50/3					
Dimensions	L		605			800	900
	W	mm	290			400	500
	H		620			720	875
Weight	kg.	35	35	40	80	90	90

\*All specifications are subject to change due to continuous R&D

## Technical Specifications (High Pressure Water Based – Upto 120°C)

MODEL	UNIT	TAC-9P	TAC-12P	TAC-18P	TAC-27P	TAC-36P
Heating Capacity	kW	9	12	18	27	36
Outlet Temp. Range <sub>(Max.)</sub>	°C	20 to 140				
Tank Capacity	Ltr	6.5	10	10	15	15
Pump Motor	kW	0.75	1.5	1.5	1.5	2.2
Flow Rate <sub>(Max.)</sub>	LPM	20-60	50-200	50-200	110-280	110-280
Pump Pressure <sub>(Max.)</sub>	bar	5.9	3.3	3.3	3.5	3.5
Cooling		Direct Cooling				
Operating Voltage	V/Hz/Ph	415/50/3				
Dimensions	L	605	800		900	
	W	290	400		500	
	H	620	720		875	
Weight	kg.	38	80	80	90	90

\*All specifications are subject to change due to continuous R&D

## Technical Specifications (Oil Based)

MODEL	UNIT	TAC-3LT	TAC-6LT	TAC-9LT	TAC-12LT
Heating Capacity	kW	3	6	9	18
Outlet Temp. Range <sub>(Max.)</sub>	°C	40 - 150			
Tank Capacity	Ltr	15	15	50	50
Pump Motor	kW	0.95	1.3	1.3	1.3
Flow Rate <sub>(Max.)</sub>	LPM	20-40	20-60	20-60	20-60
Pump Pressure <sub>(Max.)</sub>	bar	3.8	5.2	5.2	5.2
Cooling		Indirect			
Operating Voltage	V/Hz/Ph	415/50/3			
Dimensions	L	605	605	670	670
	W	290	290	400	400
	H	620	620	800	800
Weight	kg.	35	35	70	70

\*All specifications are subject to change due to continuous R&D

# Water Chillers

**ACU Series Water Chillers** are designed to meet diversified process cooling requirements for the modern plastics industry; meant to enhance productivity and quality.

They are equipped with the latest safety features and microprocessor controls and are easy to handle and maintain.

## Salient Features

- Microprocessor based control
- PHE (Plate Heat Exchanger) evaporator
- Large size inbuilt insulated tank
- Shell & Tube/large size finned condenser
- High pressure chilled water pump
- Safety features, i.e, single phase prevention, LP/HP cut offs, anti freeze, dry running protection are present
- Audiovisual alarm to draw operator’s attention
- Crank case heater to prevent liquid migration of refrigerant into compressor
- Filter drying to ensure moisture free system
- Water re-feeding valve to automatically maintain level in the tank

## Technical Specifications

Material	Compressor Capacity	Installed Power	Max. Flow Rate	Overall Dimension	Weight (Approx.)
	TR	kW	LPM	L*W*H (MTR)	Kg.
A-50-A	5.4	6.9	70	1.16*0.9*1.35	400
A-75-A	7.4	7.8	90	1.16*0.9*1.35	500
A-100-A	10.3	10.8	130	1.16*0.9*1.35	700
A-120-A	11.1	11.6	140	1.5*1.05*1.65	720
A-150-A	12.9	13.6	165	1.7*1.2*1.85	800
A-175-A	17.4	18.2	220	1.7*1.2*1.85	830
A-220-A	22.2	22.8	280	1.7*1.2*1.85	870
A-250-A	26.2	22.8	330	1.7*1.2*1.85	900
A-50-W	6	6.3	75	1.16*0.9*1.35	350
A-65-W	6.6	6.7	80	1.16*0.9*1.35	365
A-75-W	7.7	7.6	100	1.16*0.9*1.35	400
A-85-W	8.6	7.4	100	1.16*0.9*1.35	450
A-100-W	10	8.9	125	1.16*0.9*1.35	650
A-120-W	11.9	10.4	150	1.5*1.2*1.65	700
A-130-W	12.8	11.2	160	1.5*1.2*1.65	730
A-150-W	15	12.6	190	1.65*1.05*1.45	800
A-200-W	20.2	17.9	250	1.9*1.4*1.6	850
A-250-W	26	21.8	325	2*1.45*1.62	900
A-300-W	31	26.7	400	2.15*1.2*2.15	950

# Industry 4.0

## Turnkey Automation

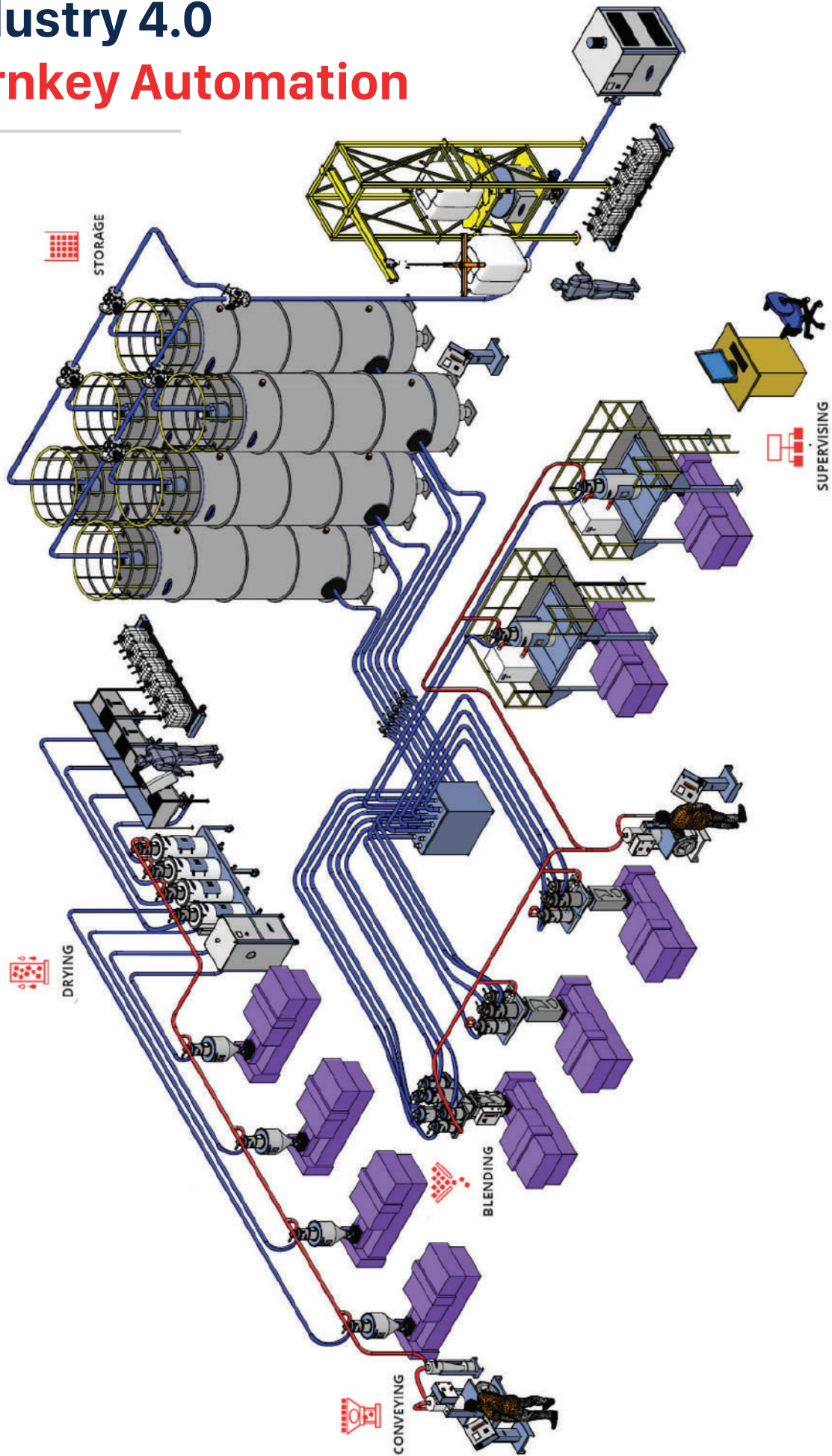



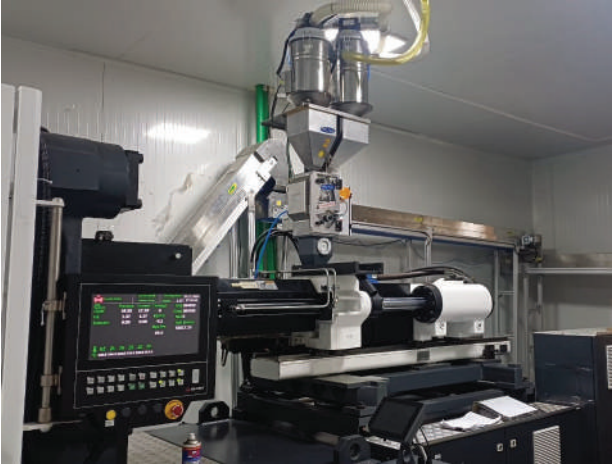

# Installations





Drying | Conveying | Dosing & Blending | Heating & Cooling | Recycling | Automation



**Aerodry Plastics Automation Pvt. Ltd.**

**JV with Ferlin Plastics Automation B.V., The Netherlands**